

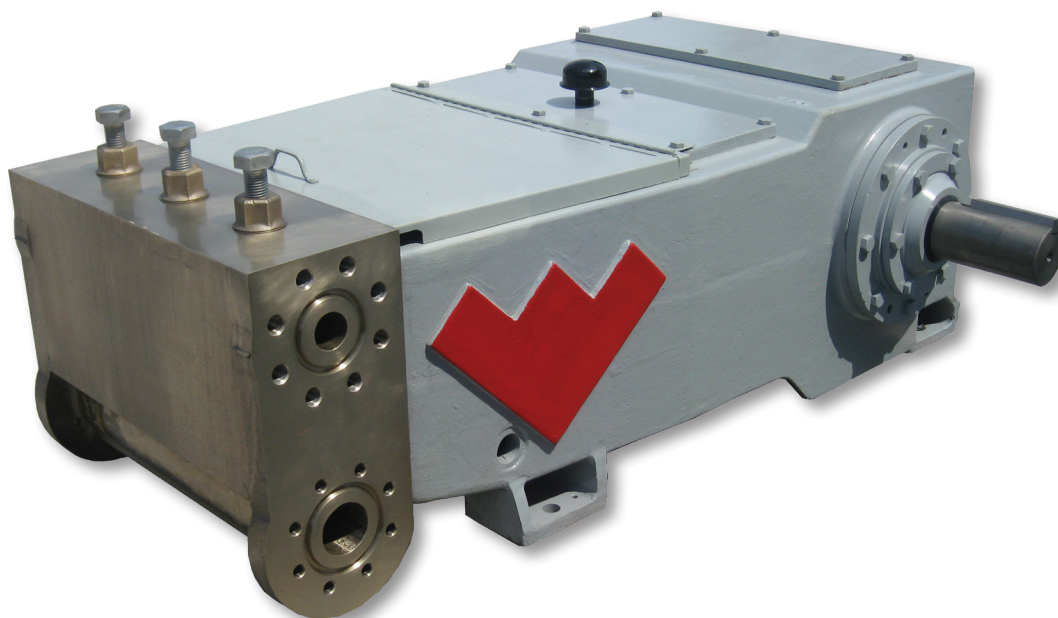

Model W165 Triplex Power Pump

Weatherford's Model W165 is a single-acting triplex plunger pump rated at 165 HP in continuous duty service. This versatile pump is offered with a variety of material and design options that enable it to be used in a wide range of applications.



Applications

- Amine gas sweetening
- Ammonia
- Chemical injection
- Core drilling
- Crude transfer
- Detergent and soap slurries
- Dust suppression
- Frac fluid recovery
- Glycol gas dehydration
- High-pressure washdown
- Horizontal directional drilling
- Hot-oil truck injection
- Hydrostatic testing
- Light hydrocarbon transportation
- Machine tool coolant
- Methanol injection
- Municipal jetting
- Oil production
- Polymer flood
- Produced water disposal
- Pulp and paper
- Reverse osmosis
- Secondary recovery
- Steam boiler feed
- Steel mill descaling
- Water injection



Model W165 Triplex Power Pump

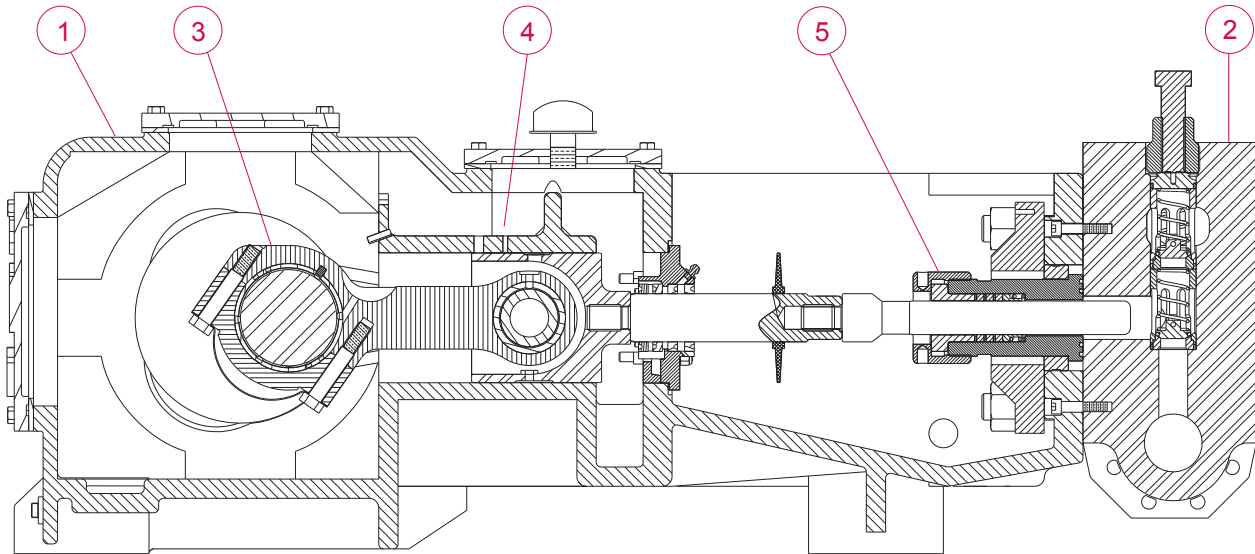

Features, Advantages and Benefits

1. The graphite flake microstructure of the cast iron power frame ensures robust, fatigue-free durability and excellent wear resistance of moving surfaces.
2. All fluid cylinders are made from forged carbon steel, duplex stainless-steel, or cast nickel-aluminum-bronze material for increased durability and extended life.
3. Critical components—crankshafts, connecting rods, crossheads, and bearings—are comparatively larger than industry-standard components, enabling them to withstand continuous duty service and harsh operating conditions.
4. The oil trough is designed to evenly lubricate the crossheads and wrist-pin bearings during operation to reduce wear and extend component life. Pump vendors often exclude this critical feature to simplify the design and reduce the cost of the power end.
5. A variety of packing arrangements are available to meet the requirements of any application:
 - a. Standard, manually adjustable packing.
 - b. Optional spring-loaded packing does not require manual adjustment.
 - c. Optional stuffing-box design that minimizes fluid and vapor leakage to atmosphere for critical fluids.



Model W165 Triplex Power Pump

Specifications

Pump Model	Plunger Size (in./mm)	Displacement (gal/rev)	Rated Pressure (psi/MPa)	Rated Capacity GPM (BPD)					
				100 RPM	200 RPM	250 RPM	300 RPM	350 RPM	400 RPM
W165H	1.500 38	0.1147	5,000 34.5	11.5 (393)	22.9 (787)	28.7 (984)	34.4 (1,180)	40.2 (1,377)	45.9 (1,574)
	1.625 41	0.1347	4,730 32.6	13.5 (462)	26.9 (923)	33.7 (1,154)	40.4 (1,385)	47.1 (1,616)	53.9 (1,847)
	1.750 44	0.1562	4,070 28.1	15.6 (535)	31.2 (1,071)	39.0 (1,339)	46.9 (1,606)	54.7 (1,874)	62.5 (2,142)
	1.875 48	0.1793	3,550 24.5	17.9 (615)	35.9 (1,229)	44.8 (1,537)	53.8 (1,844)	62.8 (2,152)	71.7 (2,459)
	2.000 51	0.2040	3,120 21.5	20.4 (699)	40.8 (1,399)	51.0 (1,749)	61.2 (2,098)	71.4 (2,448)	81.6 (2,798)
W165M	2.000 51	0.2040	3,120 21.5	20.4 (699)	40.8 (1,399)	51.0 (1,749)	61.2 (2,098)	71.4 (2,448)	81.6 (2,798)
	2.125 54	0.2303	2,760 19.0	23.0 (790)	46.1 (1,579)	57.6 (1,974)	69.1 (2,369)	80.6 (2,764)	92.1 (3,158)
	2.250 57	0.2582	2,460 17.0	25.8 (885)	51.6 (1,770)	64.5 (2,213)	77.5 (2,656)	90.4 (3,098)	103.3 (3,541)
	2.375 60	0.2877	2,210 15.2	28.8 (986)	57.5 (1,973)	71.9 (2,466)	86.3 (2,959)	100.7 (3,452)	115.1 (3,945)
	2.500 64	0.3187	2,000 13.8	31.9 (1,093)	63.7 (2,186)	79.7 (2,732)	95.6 (3,279)	111.6 (3,825)	127.5 (4,371)
	2.625 67	0.3514	1,810 12.5	35.1 (1,205)	70.3 (2,410)	87.9 (3,012)	105.4 (3,615)	123.0 (4,217)	140.6 (4,819)
	2.750 70	0.3857	1,650 11.4	38.6 (1,322)	77.1 (2,645)	96.4 (3,306)	115.7 (3,967)	135.0 (4,628)	154.3 (5,289)
W165L	2.750 70	0.3857	1,650 11.4	38.6 (1,322)	77.1 (2,645)	96.4 (3,306)	115.7 (3,967)	135.0 (4,628)	154.3 (5,289)
	3.000 76	0.4590	1,390 9.6	45.9 (1,574)	91.8 (3,147)	114.7 (3,934)	137.7 (4,721)	160.6 (5,508)	183.6 (6,295)
	3.250 83	0.5387	1,180 8.1	53.9 (1,847)	107.7 (3,694)	134.7 (4,617)	161.6 (5,541)	188.5 (6,464)	215.5 (7,388)
	3.500 89	0.6247	1,020 7.0	62.5 (2,142)	124.9 (4,284)	156.2 (5,355)	187.4 (6,426)	218.7 (7,497)	249.9 (8,568)
	3.750 95	0.7172	890 6.1	71.7 (2,459)	143.4 (4,918)	179.3 (6,147)	215.2 (7,377)	251.0 (8,606)	286.9 (9,836)
	4.000 102	0.8160	780 5.4	81.6 (2,798)	163.2 (5,595)	204.0 (6,994)	244.8 (8,393)	285.6 (9,792)	326.4 (11,191)



Model W165 Triplex Power Pump

Specifications (continued)

Maximum Discharge	(psi/MPa)
Model H	5,000 34.5
Model M	3,120 21.5
Model L	1,650 11.4

Crankshaft Extension	(in./mm)
Diameter	4.125 105
Length (long side)	8.12 206
Length (short side)	5.88 149
Key way	1.00 × 0.50 25 × 13
Maximum recommended sheave	50 1,270
Minimum recommended sheave	36 914

Rated power (HP)	165
Maximum speed (RPM)	400
Minimum speed (RPM)	100
Stroke length (in./mm)	5.00 127
Rated rod load (lb/kg)	9,800 4,445
Weight (lb/kg)	4,000 1,814
Oil capacity (gal/L)	8 30
Maximum fluid temperature (°F/°C)	180 82
Mechanical efficiency (%)	90

Model W165 Triplex Power Pump

W165 Selection Graph

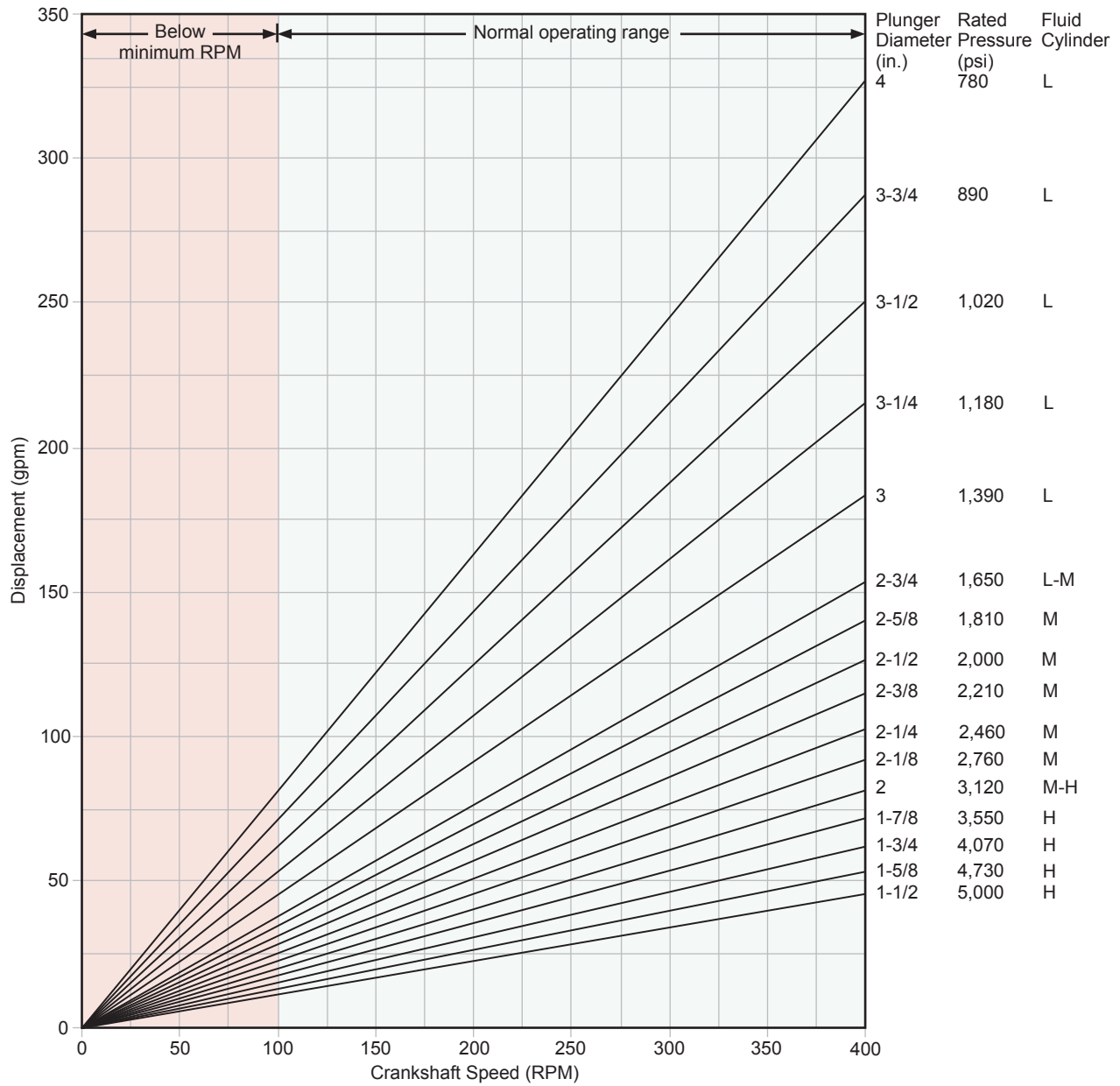

5.00-in. stroke, maximum rod load 9,800 lb (4,445 kg)

Model W165 Triplex Power Pump

General Dimensions

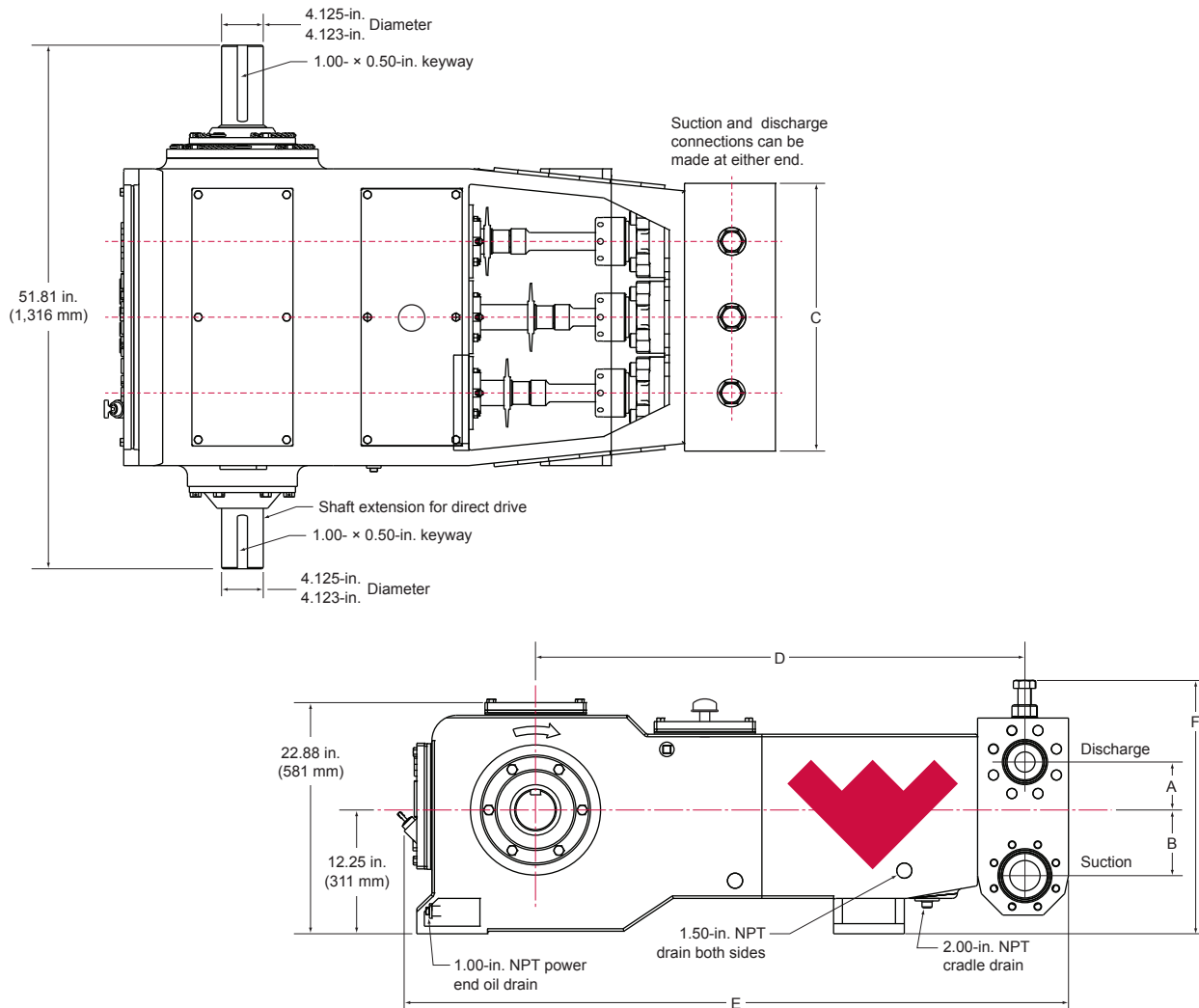

Pump Model	Flange Connections (in./mm)		Dimensions (in./mm)					
	Discharge Connection Sizes	Suction Connection Sizes	A	B	C	D	E	F
W165L	3 (76.2) API-2000 RJ	6 (152.4) ANSI-150 FF	5.69 145	7.63 194	27.75 705	48.75 1,238	65.75 1,670	23.00 584
W165M	2 (50.8) API-5000 RJ	4 (101.6) ANSI-150 FF	4.75 121	6.50 165	26.50 673	48.38 1,229	64.88 1,648	25.31 643
W165H	2 (50.8) ANSI-2500 RJ	3 (76.2) API-2000 RJ	4.75 121	6.50 165	26.50 673	48.38 1,229	64.25 1,632	25.31 643



Model W165 Triplex Power Pump

Materials of Construction

Fluid Cylinder: The W165 pump is offered with 4140 carbon steel, 955 nickel-aluminum bronze, and 2205 duplex stainless-steel, fluid-cylinder materials as standard, with 420, 304, and 316L stainless-steel materials available on special request.

Plungers: Weatherford provides tungsten-carbide, coated plungers as standard on all versions of the W165 pump. Weatherford offers optional solid ceramic, or ceramic-coated plungers on request for special applications with pumping abrasive or corrosive fluids for superior durability.

Packing: Weatherford provides all W165 pumps with braided Teflon®-Kevlar® packing as standard. This versatile packing is suitable for a wide variety of fluids and can work with or without external lubrication in most services. Optional packing styles and materials may be available as options to provide maximum performance and durability for almost any fluid and operating condition.

Trim rings: Trim rings located inside the stuffing box can include throat bushings, lantern glands, follower rings, and adjusting nuts. Weatherford provides bronze trim rings as standard on all pumps; however, optional materials are available to meet the needs of specific fluids. All iron trim rings are offered when pumping amines or fluids that contain H₂S.

Seals: The W165 pump is provided with EPDM O-ring seals as standard. This versatile material is compatible with a wide range of common industrial and oilfield fluids and has excellent temperature and abrasion-resistant properties. Weatherford offers Viton®, Aflas®, and HNBR compounds as options to meet specific fluid compatibility and operating temperature requirements.

Special Notes

1. Capacities shown are based on 100 percent volumetric efficiency. Actual capacities are lower, based on discharge pressure and fluid compressibility.
2. Operating power required by the pump is calculated by the formula: $HP = (psi \times gpm) / 1,543$, where psi is the actual operating pressure in psi units, and gpm is the actual pumping capacity in gpm.
3. Maximum operating speeds are based on pumping nonabrasive fluids with viscosities similar to water. Consult Weatherford for operating speed recommendations for viscous or abrasive liquids.
4. Dimensions shown are typical and should not be used for fabrication purposes. Optional flanged connections are shown for reference. Inlet and discharge connections can be on either side of the fluid cylinder.
5. Special designs and materials are available for operation above 180°F (82°C).
6. API-674 and NACE-compliant designs are available on request. Consult Weatherford for specific details and exceptions to these standards.
7. Standard plunger sizes are shown; however, other sizes may be available on request. Consult Weatherford for performance and pressure ratings.
8. Consult Weatherford for assistance with pump selection on applications where actual operating inlet pressures are greater than 10 percent of the rated discharge pressure of the pump model selected.
9. For operation below 200 RPM, an auxiliary lubrication system is required.
10. Spherical valves must be installed when the pump is fitted with 4.00-in. plungers.

Teflon, Kevlar, Viton and Aflas are registered trademarks of their respective owners.